

CONTENT

Chapter 1 Safety.....	3
1 Precautions for safety.....	3
1-1 Precautions for safety.....	3
1-2 Label of warning.....	3
2 Safety device.....	4
2-1 Detail rules.....	4
Chapter 2 General.....	6
1 Outline of mechanism.....	6
1-1 Purpose of use.....	6
1-2 Main technical parameters.....	6
1-3 Accessories with the machine.....	7
1-4 Outlook drawing.....	7
Chapter 3 Set-up, operation and maintenance.....	9
1 Set-up.....	9
1-1 Way of set-up and flow sequence.....	9
1-2 Place and conditions where the machine is placed.....	10
2. Operation.....	11
2-1 Cutting flow.....	11
2-2 Operation panel.....	12
2-3 Datum selection.....	13
2-4 Cutting mode.....	14

2-5 Set the parameters	22
2-6 Way of operations and flow.....	29
2-7 Way to load and unload the rotary blade assembly	30
2-8 Way of adjustment to cut different thickness of paper	32
3 Troubleshooting	33
3-1 Safety cover fails.....	33
3-2 Settlement of paper jamming	33
3-3 Long blade jam	34
3-4 Black Mark■ not detected	35
3-5 Mark sensor failed.....	35
3-6 Paper is too narrow	36
3-7 Bad paper feeding	37
4 After-care	38
4-1 Warranty	38
4-2 Maintenance service.....	38
4-3 Units with specified replacement periods	38
5 System troubleshooting analysis	39

Chapter 1 Safety

- To prevent accidents and dangers from happening, the operators are required to get familiar with the precautions of safety and completely understand the content therein before set-up, operation, check and maintenance.

1 Precautions for safety

1-1 Precautions for safety







To prevent any accidents, please follow the precautions below strictly.

- (1) Have the ground-wire of the power supply well grounded.
- (2) In case of a long hair with the operator, please tie it when to operate the machine in order to avoid being rolled into it.
- (3) Do not touch the electric points and the loops with wet hand.
- (4) When to stop use of the machine, please cut off the power.
- (5) In case of an abnormality with the machine, cut off the power directly.
- (6) Please contact with the dealer when there is any question about the way of operation or work.
- (7) In case of a failure with the machine, please contact with the dealer, if it is no way to settle upon the way noted therein.

1-2 Label of warning

Operators are required to pay special attention to the places fitted with the warning labels during operation, check and maintenance.

Description of the warn labels:

A	 Attention  Possible to get clamped, do not touch it during movement.	Take care not to get clamped <ul style="list-style-type: none"> ● Please do not touch the moving part.
B	 Attention  Do not touch it in order to avoid high voltage electricity.	Take care not to get electric shock <ul style="list-style-type: none"> ● Pay attention to the electric shock. Please take care not to get electric shock as there is a power when to maintain and check the machine. ● Do not touch it with wet hand.
C	 Attention  Possible to get injury during movement, do not touch the edge of the cutter with hand.	Pay attention to the edge of the cutter <ul style="list-style-type: none"> ● Pay special attention to the edge of the cutter when to treat it.

2 Safety device

To prevent accidents and dangers, safety devices are set on the positions for the operator to be possible to touch.

2-1 Detail rules

2-1-1 Detail rules and operation limit

Both fixing and lock covers are set to prevent any tools and clothes from being rolled into the machine due to carelessness of the operator.

Never do operation when the covers are opened. Once the lock cover is opened, the machine will stop moving right away.

2-1-2 Lock cover, fixing cover

1. Upper cover
2. Switch of lock cover
3. Side cover of operation (left-side cover)
4. Right-side cover
5. Front cover
6. Front cover
10. Front cover

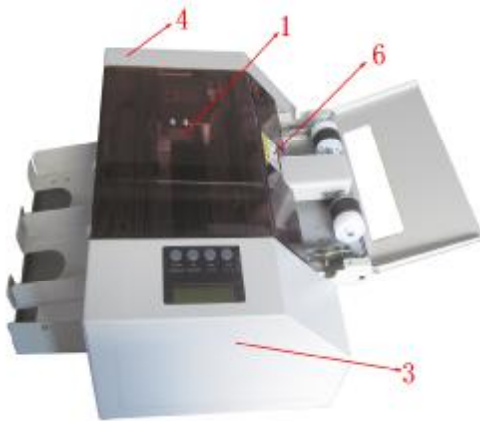

Fig. 1-1 Frontal

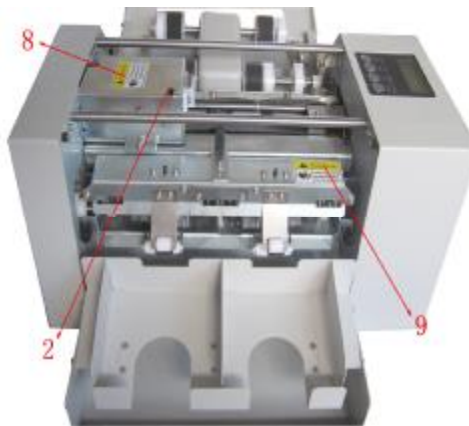

Fig. 1-2 Top



Fig. 1-3 Back

Label of warning

6. Take care of being clamped
7. Take care of cutter edge
8. Take care of cutter edge
9. Take care of cutter edge

10. Take care of electric shock

Chapter 2 General

In this chapter, information related to “card cutting machine” is recorded.

1 Outline of mechanism

1-1 Purpose of use

To have the printed name cards or photos automatically cut into suitable sizes.

1-2 Main technical parameters

Way of cutting	Longitudinal: rolled cutting by a roller; horizontal: cutting by long blade
Way of paper feeding	Automatic paper feeding in double rubbing
Size of paper	A4(297×210mm)
Thickness of paper	Common paper: 180g/m ² ----350g/m ²
Cutting speed	For name cards, about 100pcs/3min
Cutting size	Longitudinal:(89, 85,90,95)mm Horizontal:(45;50;54;90;95;127)mm;or40-250mm,customize)
Volume of paper	Maximum 12pcs (about 0.25mm thick) for name cards or total thickness 3mm
Volume of name card	180g/m ² 90×2pcs 250g/m ² 70×2pcs
Mechanical dimension	430mm×385mm×220mm (L x W x H)

Operating environment	-15°C ~ +40°C humidity 35% ~ 70%
Weight	About 13.5Kg
Power supply	AC 90~260V, 50/60HZ, 0.5A

1-3 Accessories with the machine

Please confirm the accessories below at unpacking.

No	Item	Quantity	Remark
1	Operating instructions	1	
2	Name card case	1	For collecting name cards
3	Cross Screwdriver	1	
4	Synchronous belt	1	Used for paper thickness adjustment unit
5	Paper rubbing wheel	1	
6	Paper feeding wheel	4	

1-4 Outlook drawing

Title of main parts

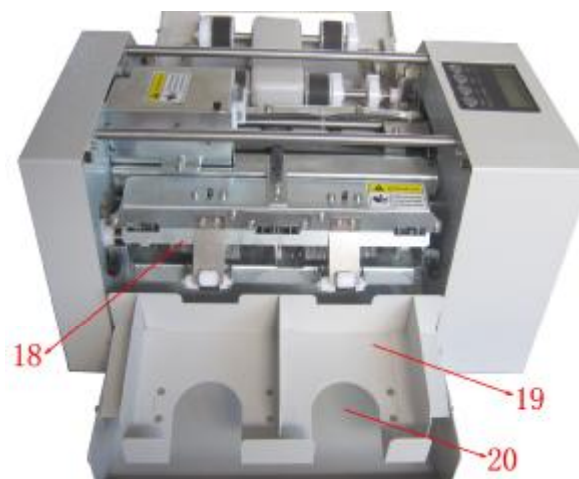
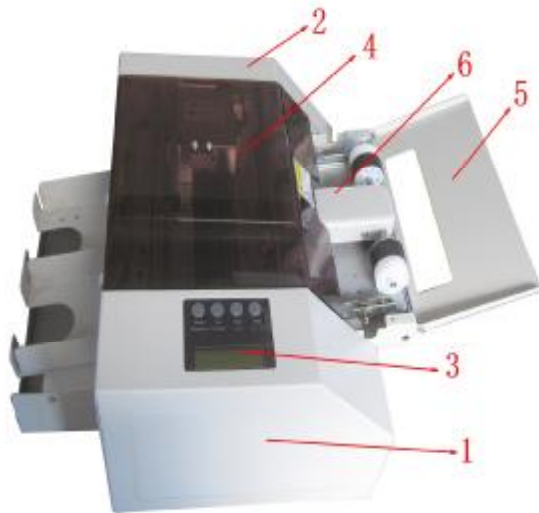

- | | |
|--|--|
| 1. left-side cover | 2. right-side cover |
| 3. operation panel | 4. upper cover |
| 5. paper feeding tray | 6. paper feeding wheel with double rubbing |
| 7. power switch | 8. frontal cover |
| 9. power wire | 10. Lock nut |
| 11.12. paper thickness adjustment needle | |
| 13. left paper guide plate | |
| 14. right paper guide plate | 15. paper rubbing wheel |

16. rotary blade

17. long blade

18. static-electric preventing hair

19. card collecting case

20. waste paper collecting case

Chapter 3 Set-up, operation and maintenance

In this chapter, the matters related to the machine set-up and the daily work flow is recorded.

1 Set-up

1-1 Way of set-up and flow sequence

(1) Take the machine out of the package.

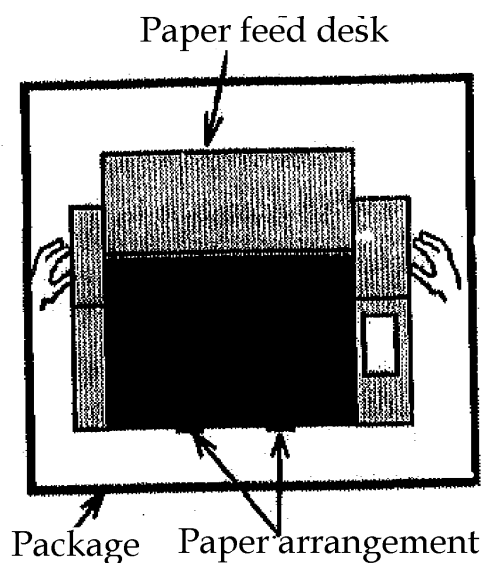

(2) Place it on a safe, solid, fixed and stable working table.

 **Attention**: Release both hands at the same time.

(3) Insert the name card collecting case from the back of the machine, then place it flatly.

 **Attention**: Insert it in completely and let it touched with the

magnetic switch.

- (4) Make the ground-wire grounded surely in order to eliminate the static electricity.



: Electric shock may occur in the case of an electric leak.

- (5) Please make sure the power switch to be in good connection.

1-2 Place and conditions where the machine is placed

Please use this machine in the place as below:

- Horizontally fixed place
- Well ventilated place
- Having a proper workable space around the machine.

As this machine is made with precise mechanism and electronic elements, a failure may occur with it if used in the place as below:

- Direct sunshine
- Mists often happening
- Wetted
- Available with fire
- Easily made wet by water
- Close to a cold-warm house
- Available with vibration



- Please do not have any other plugs inserted in the socket used specially for the machine.
- Use a static-electricity preventing cover and a humidifier for the place where the static electricity happens easily.
- Do not place the machine on a table smaller than itself.

2. Operation

2-1. Cutting flow

Rake cutting test upon the flow below in the initial use.

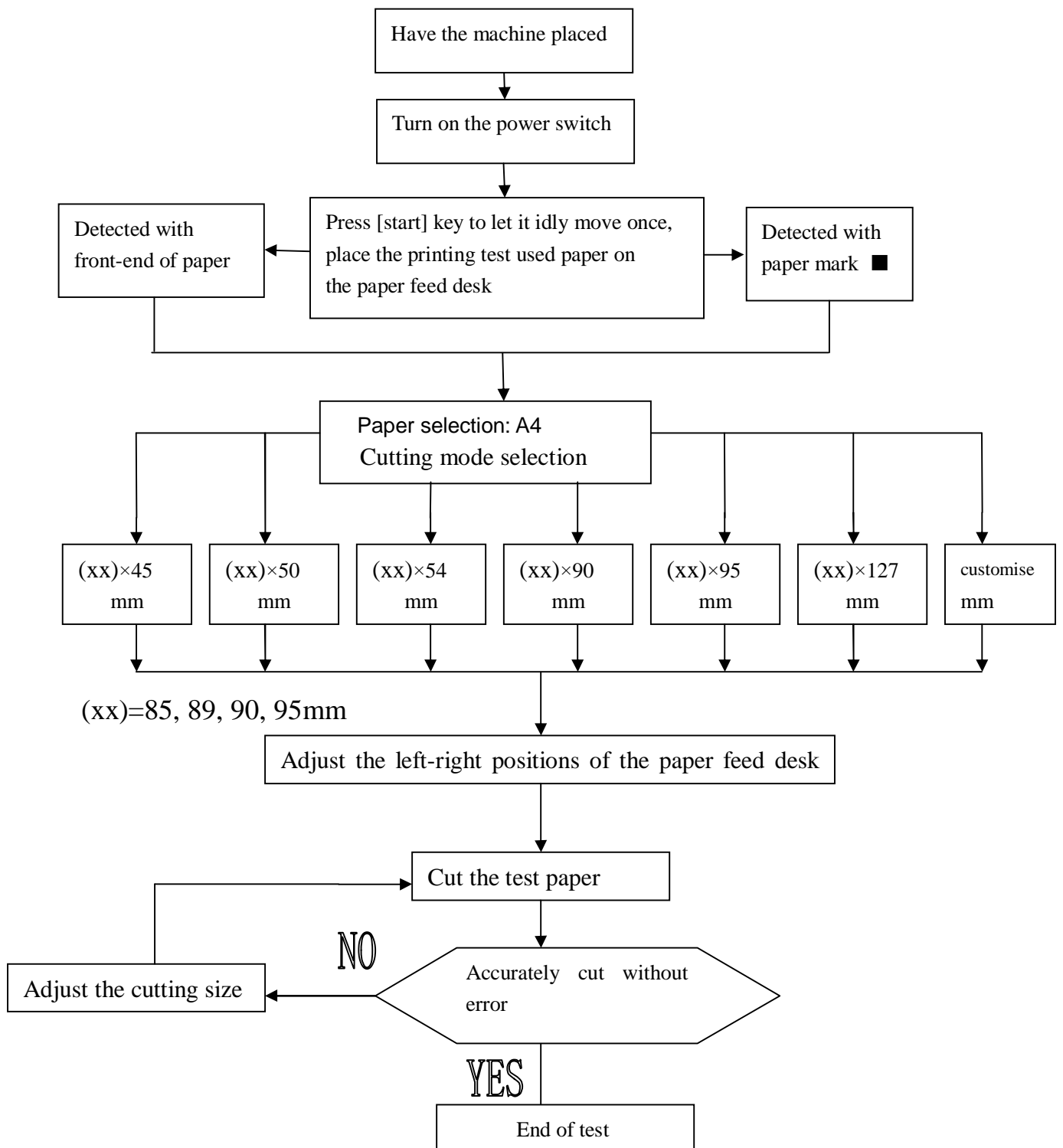

2-2 Operation panel

(1) Back of the panel

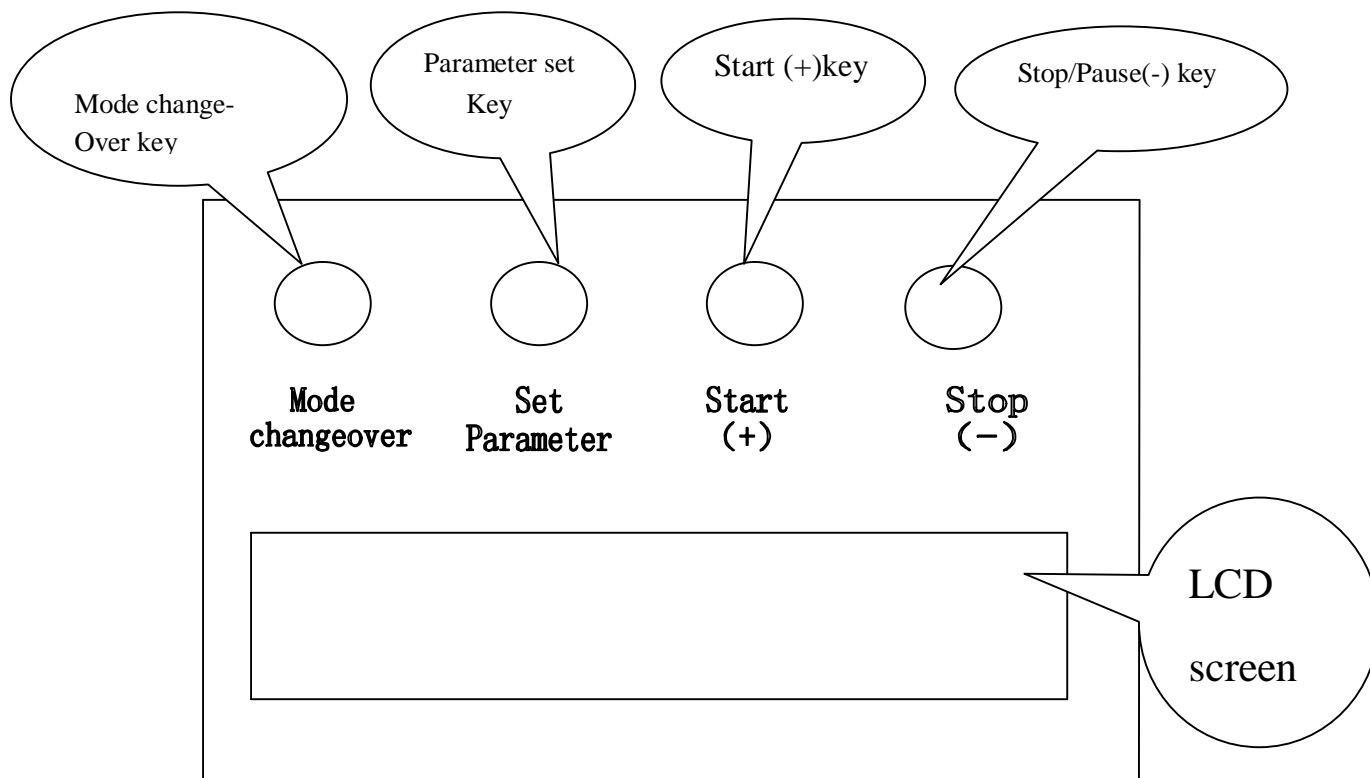

- Mode changeover key: Standby, changeover the cutting mode ,Return standby state when set parameter.
- Parameter setting key: used to adjust the cutting size and set the cutting paper number
- Start (+) key: start cutting in the standby state; increase the value in the cutting size adjustment
- Stop/Pause (-) key: stop cutting during work; decrease the value in the cutting size adjustment
- LCD screen: display the cutting mode and counting

(2) LCD display

After the power is turned on, the machine starts initialization and then goes into the standby state. The said state means the machine has finish initializing but not entered into the cutting work (the machine

stops), the LCD in the standby state will display:

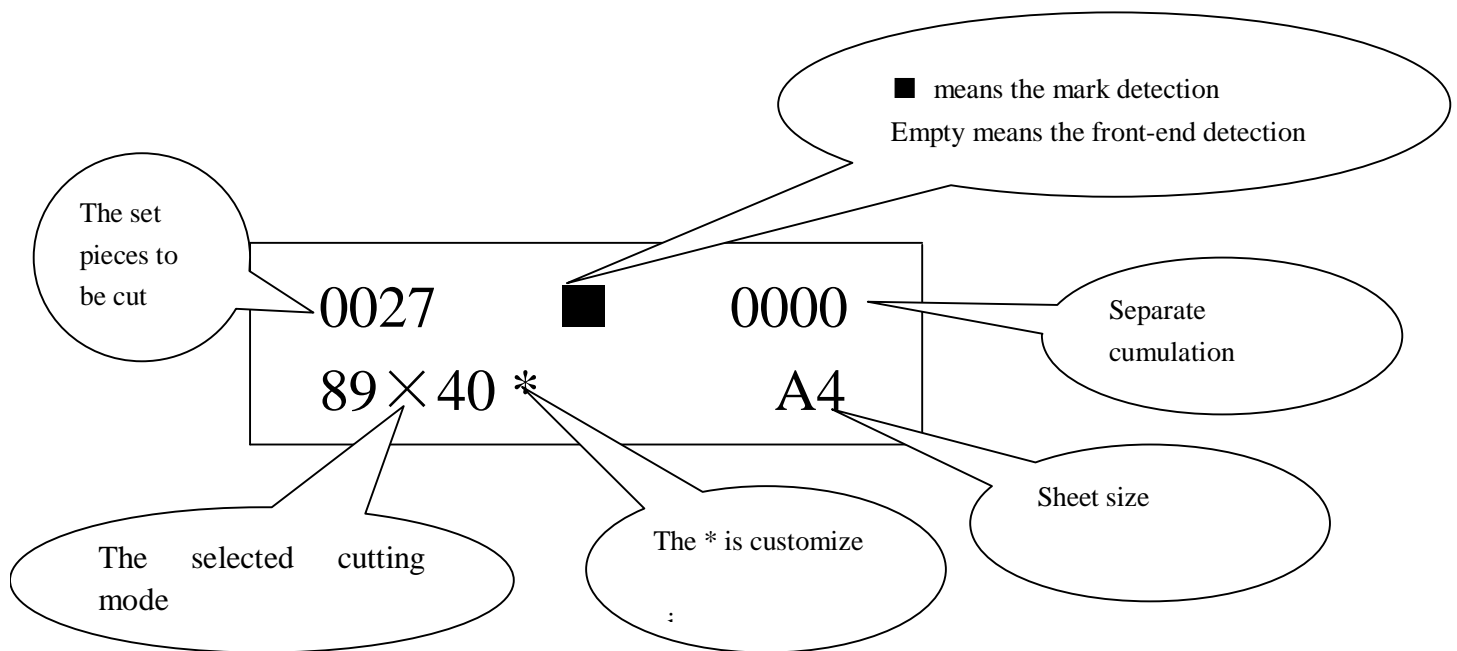

2-3 Datum selection

2-3-1 Two selections of datum

- 1) Frontal end: take the utmost frontal end of the paper as the datum for cutting;
- 2) Mark■: take the pre-printed mark as the datum for cutting

2-3-2 Printing condition with the paper mark■

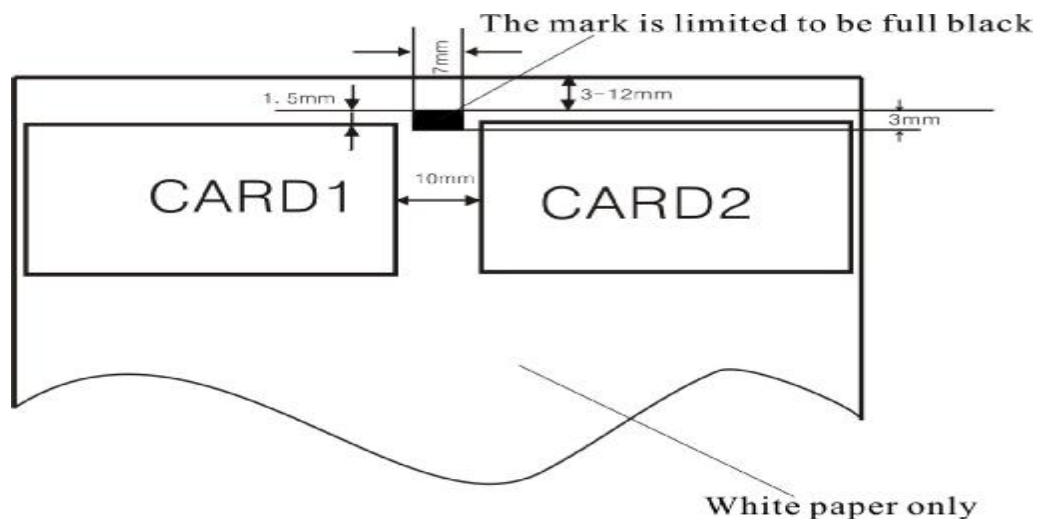

2-4 Cutting mode

2-4-1 Rotating cutter group selection

- ① C-2-85, cutting 2 columns, cutting width 85mm, optional assembly
- ② C-2-89, cutting 2 columns, cutting width 89mm, standard allocation
- ③ C-3-90, cutting 2 columns, cutting width 90mm, optional assembly
- ④ C-2-95, cutting 2 columns, cutting width 95mm, optional assembly

Please note the type of the rotating cutter group at order.

2-4-2 Cutting mode

- ① 89×45mm, use C-2-89 rotating cutter group, 2 columns 5 rows total 10 cards;
- ② 89×50mm, use C-2-89 rotating cutter group, 2 columns 5 rows total 10 cards;
- ③ 89×54mm, use C-2-89 rotating cutter group, 2 columns 5 rows total 10 cards;
- ④ 89×90mm, use C-2-89 rotating cutter group, 2 columns 3 rows total 6 cards;
- ⑤ 89×95mm, use C-2-89 rotating cutter group, 2 columns 3 rows total 6 cards;
- ⑥ 89×127mm, use C-2-89 rotating cutter group, 2 columns 2 rows total 4 cards;
- ⑦ 89×(xx)mm, use C-2-89 rotating cutter group, xx=40—250mm, customize

Attention: The red border and the mark dimension of print size is the cards print size. The black dashed and the mark dimension of the siz

e is the trim size. The card content should be completed within the black dashed line.

2-4-3 Cutting format

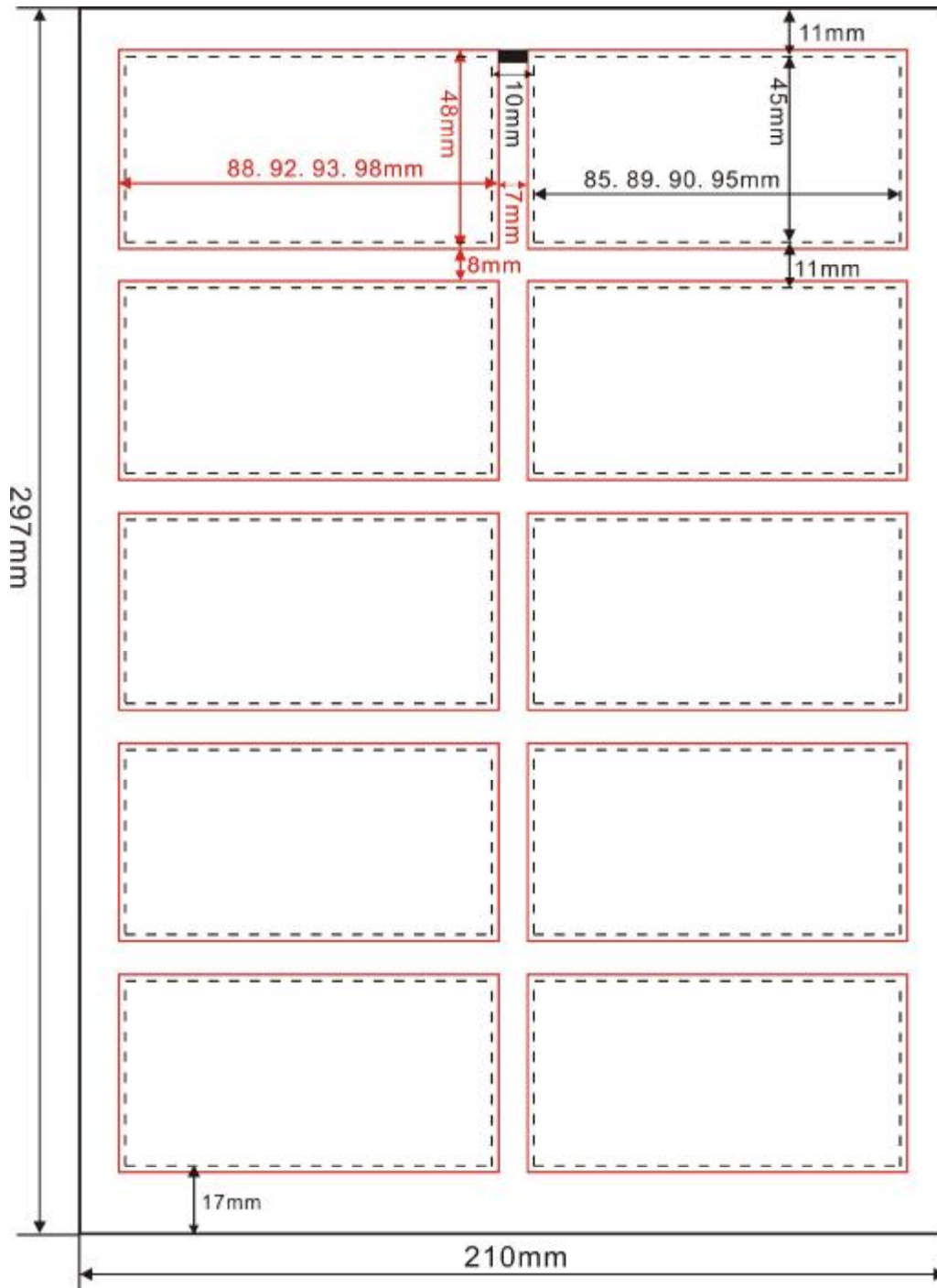

A4(210*297) (85,89,90,95)mm × 45mm

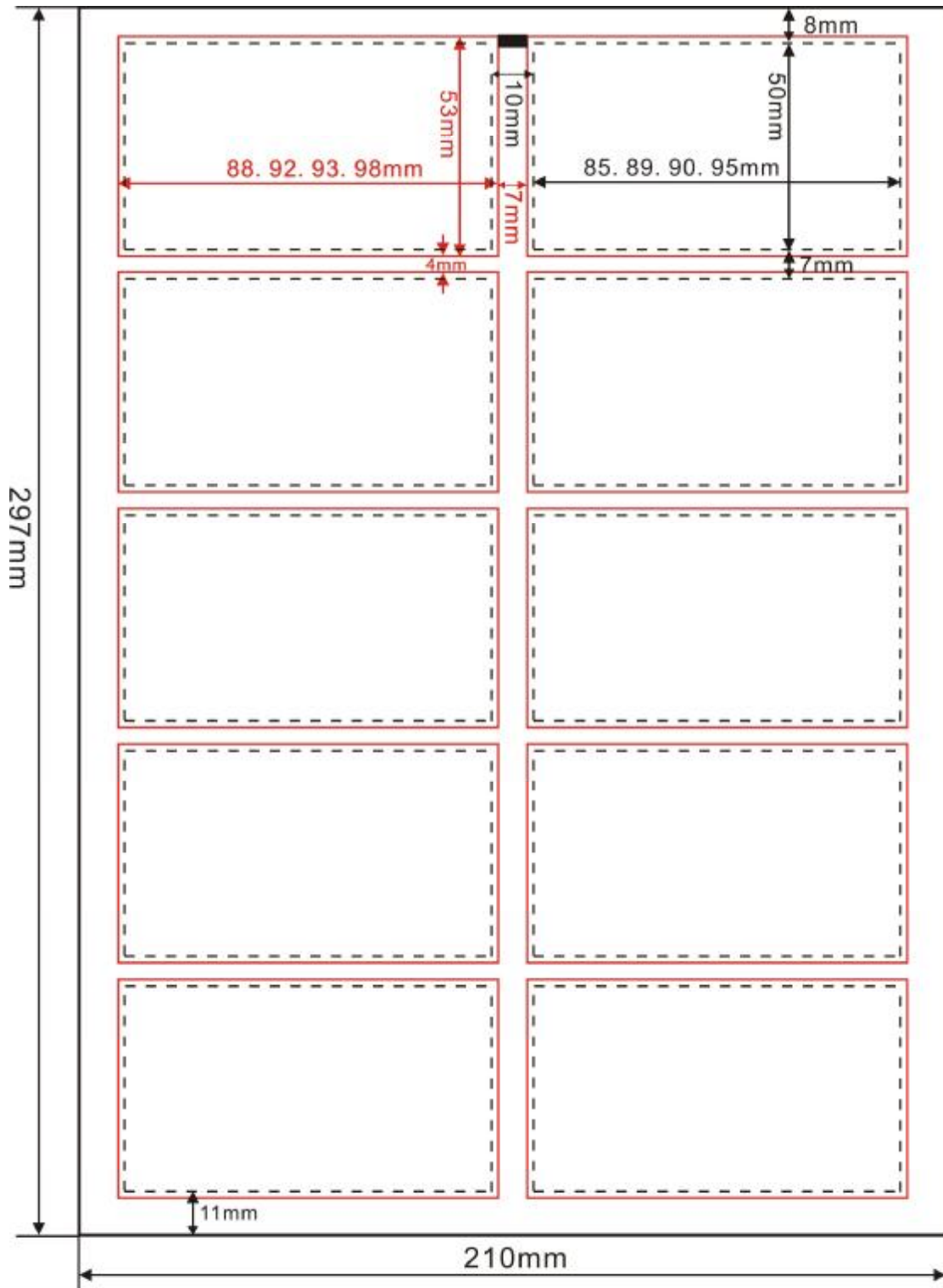

A4(210*297) (85,89,90,95)mm × 50mm

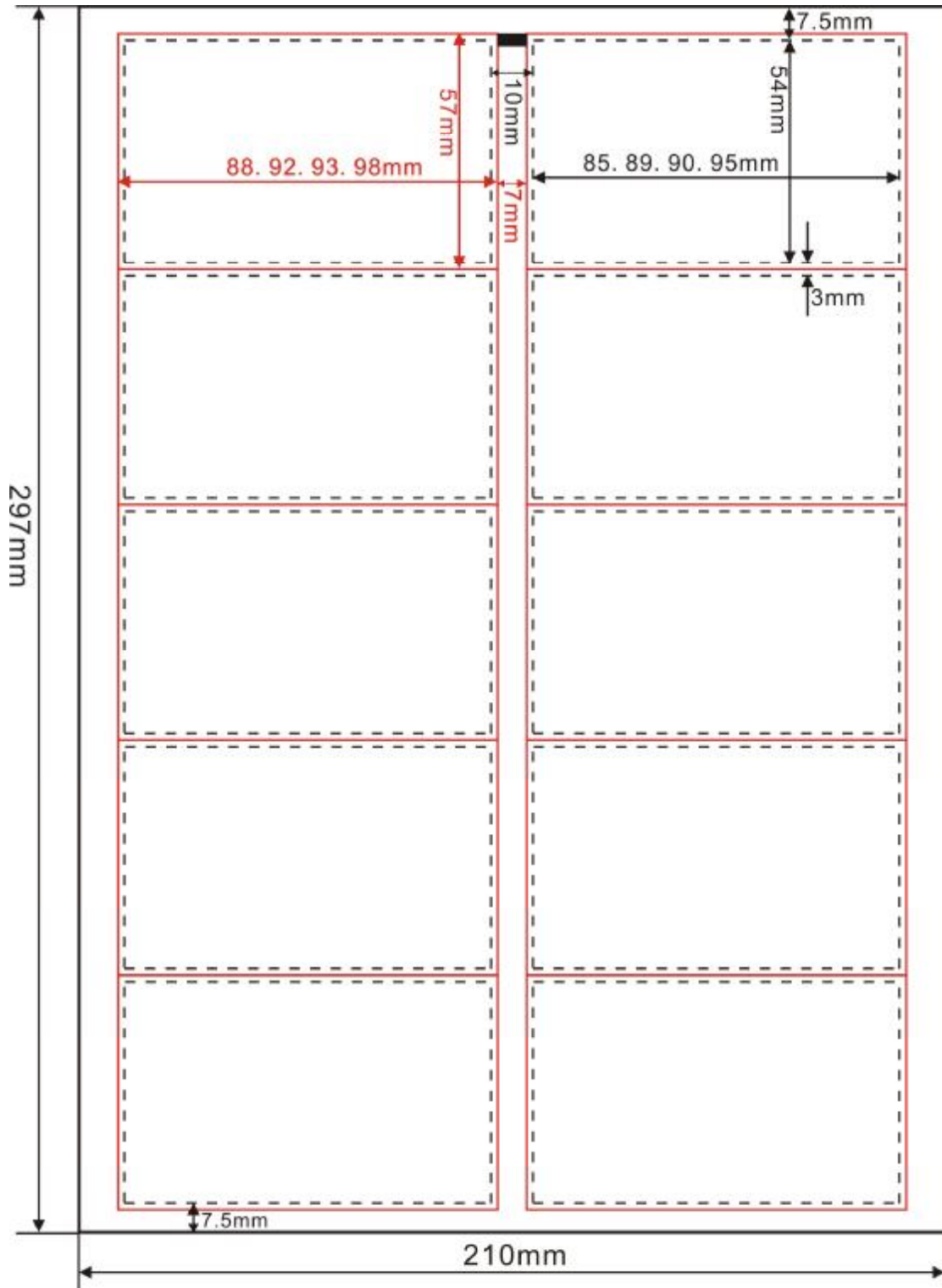

A4(210*297)

(85,89,90,95)mm × 54mm

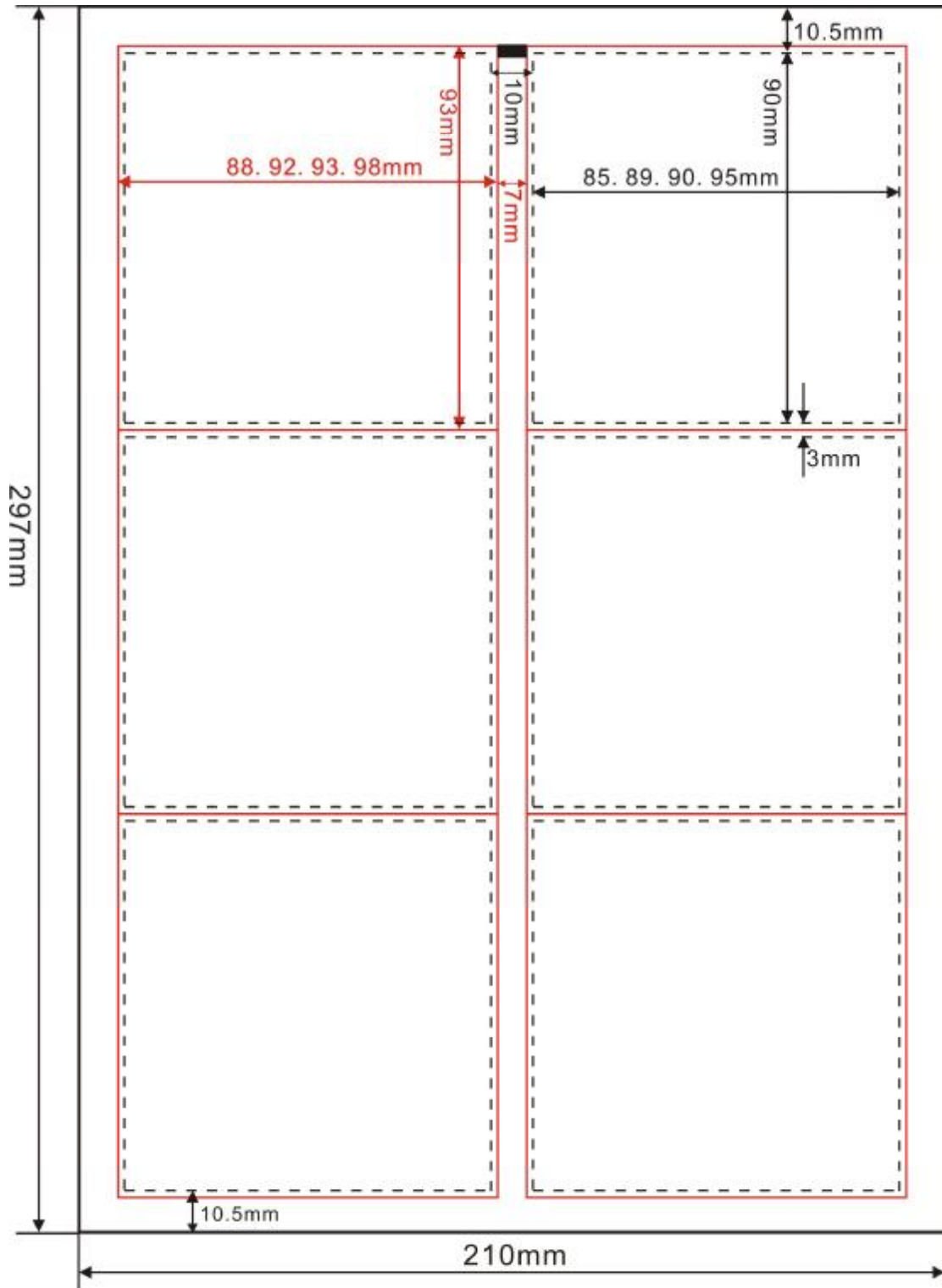

A4(210*297) (85,89,90,95)mm × 90mm

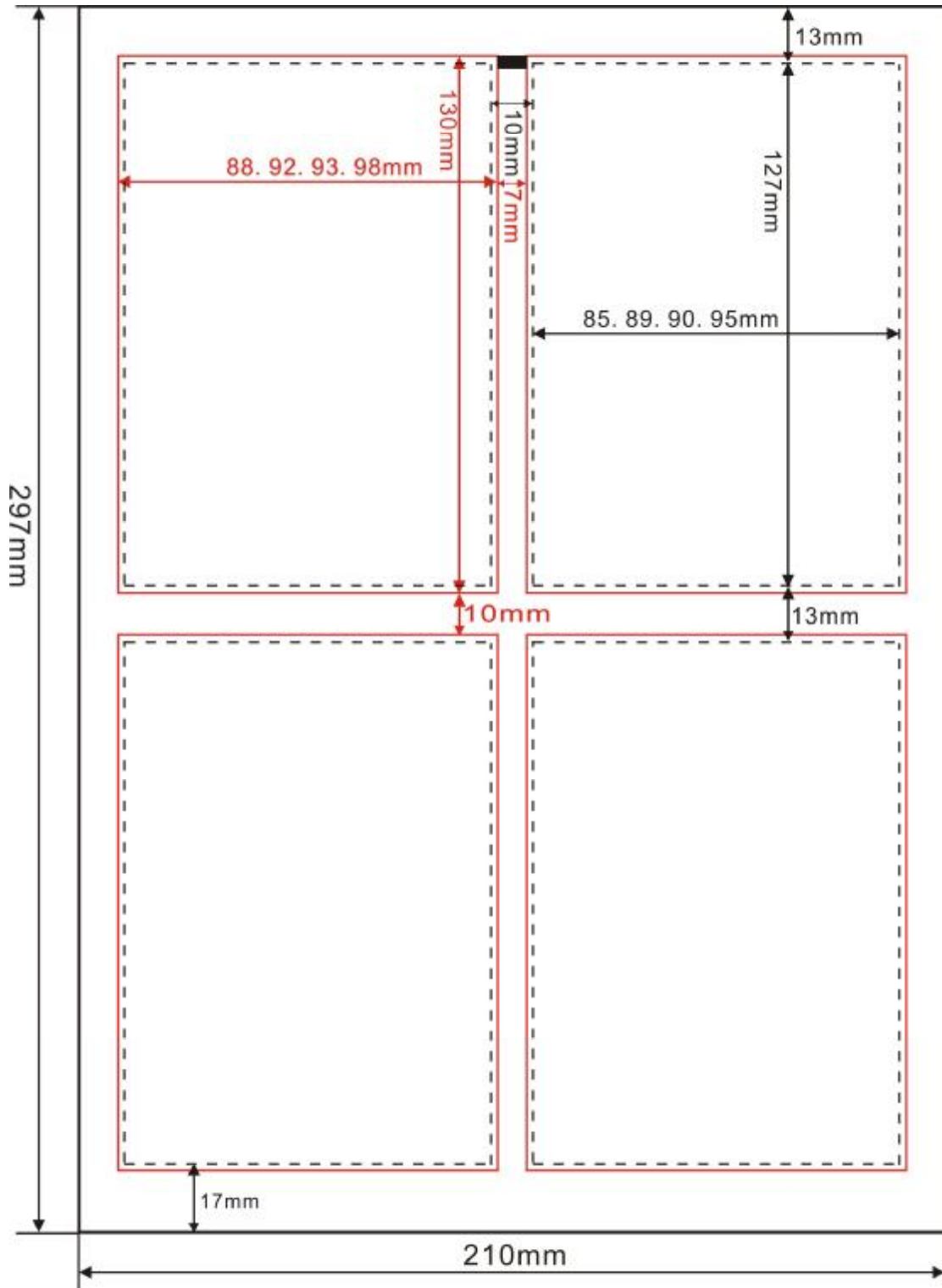

A4(210*297) (85,89,90,95)mm × 127mm

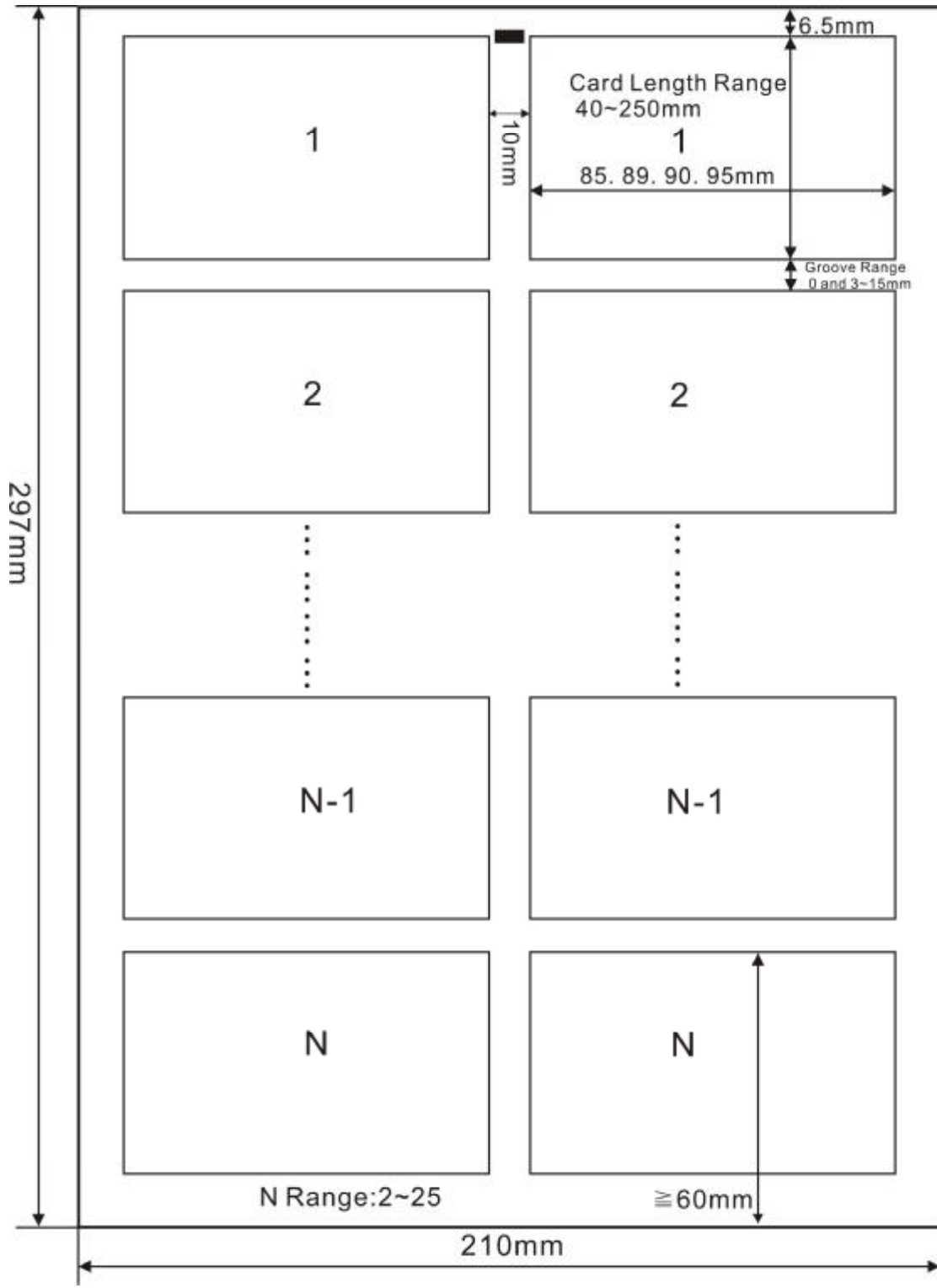

(85,89,90,95)mm × (40-250) mm; customise

2-4-4 Setting method of the cutting mode

Continually press the mold changeover key till the desired mode to be shown on the LCD screen.

2-5. Set the parameters

2-5-1 Set-up of the pieces to be cut

Set the cut pieces when several A4 papers are to be automatically cut in once cutting.

① When [Parameter setting] key is pressed one time, the LCD will show:

Cut pieces: XXXX

② Adjust it via [+] or [-] key.

③ Press the [Mode changeover] key to return to the standby state.

2-5-2 Datum selection

① When [Parameter setting] key is pressed two times, the LCD will show.

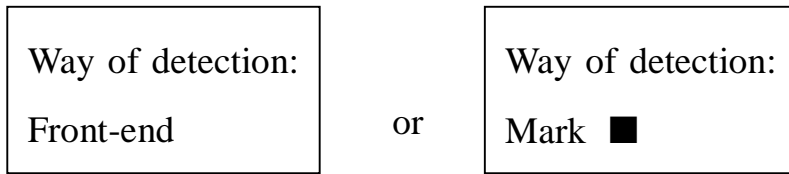

- ②Select it via [+] or [-] key.
- ③Press the [Mode changeover] key to return to the standby state.

2-5-3 Select the language

- ①When [Parameter setting] key is pressed three times, the LCD will show

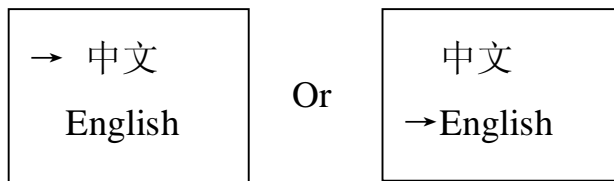

- ②Select it via [+] or [-] key
- ③Press the [Mode changeover] key to return to the standby state.

2-5-4 Adjust the size error

When an error occurred with the size of the actually cut paper, adjust [mark ■ posit comp], [First cut comp], [card length] and [gutter comp] separately.

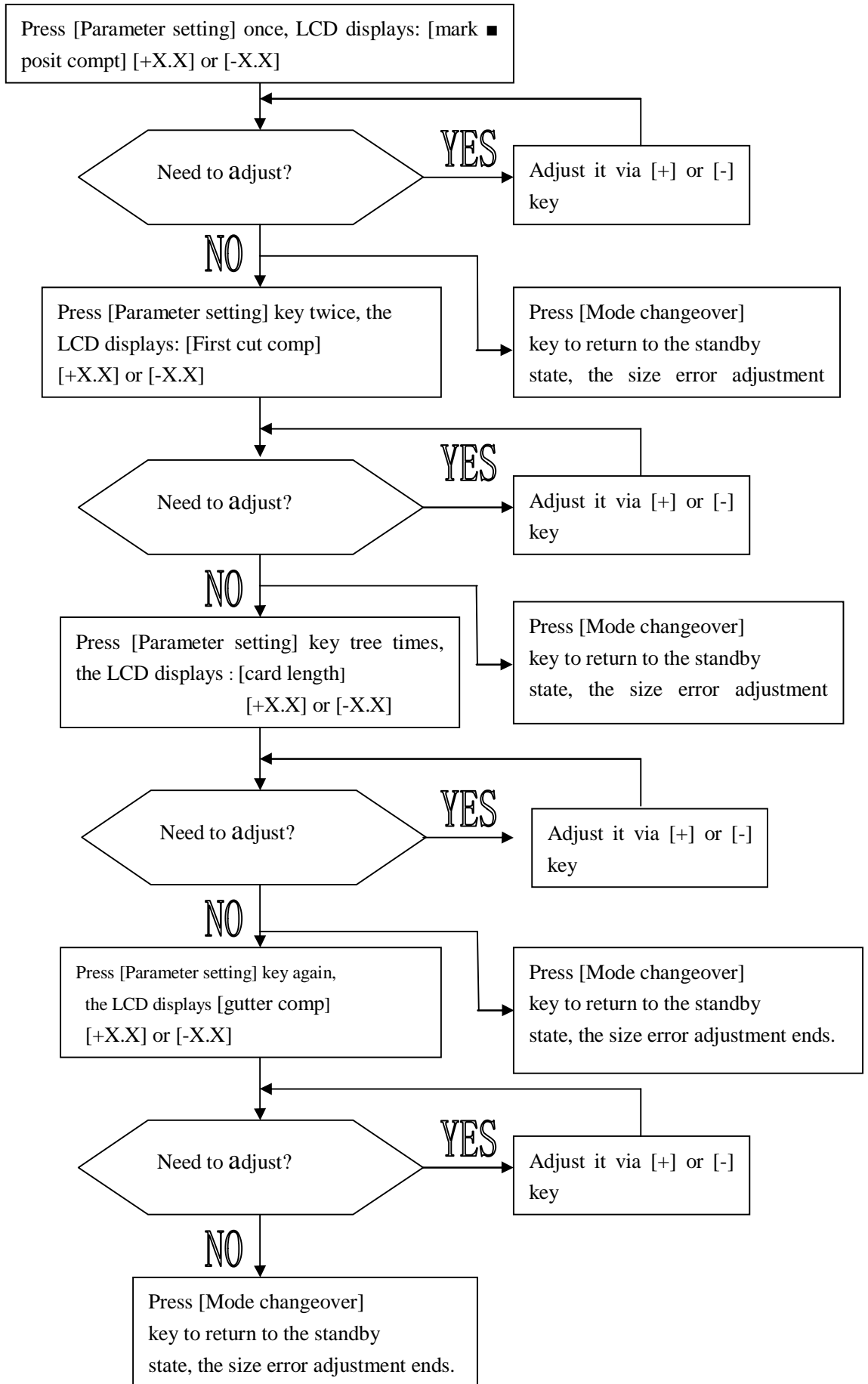

1. Mark ■ position compensation

①When [Parameter setting] key is pressed four times, the LCD will show

Mark ■ posit comp : +0.00 mm

②Select it via [+] or [-] key (Select from-2.0 to +2.0mm)

③Press the [Mode changeover] key to return to the standby state.

2. First cutting compensation

①When [Parameter setting] key is pressed five times, the LCD will show

First cut comp: +0.00 mm

②Select it via [+] or [-] key (Select from-2.0 to +2.0mm) .

③Press the [Mode changeover] key to return to the standby state.

3. Card length compensation

①When [Parameter setting] key is pressed six times, the LCD will show

Card length comp: +0.00 mm

②Select it via [+] or [-] key (Select from-2.0 to +2.0mm) .

③Press the [Mode changeover] key to return to the standby state.

4. Gutter compensation

①When [Parameter setting] key is pressed seven times,
the LCD will show:

Gutter comp: +0.00 mm

②Select it via [+] or [-] key (Select from -2.0 to +2.0mm) .

③Press the [Mode changeover] key to return to the standby state.

2-5-5 Check up the total accumulated cards

①When [Parameter setting] key is pressed eight times,
the LCD will show

Accumulated cards: XXXXXX

②Press the [Mode changeover] key to return to the standby state.

2-5-6 Sub-accumulated counting clear-up

①When [Parameter setting] key is pressed nine times, the LCD will show

Sub-accumulated cards: XXXX

②Press the [-] key to clear up the sub-accumulated counting.

③Press the [Mode changeover] key to return to the standby state.

2-5-7 Adjust the name card size

①When [Parameter setting] key is pressed ten times, the LCD will show

Slitting width:
XX

- ② Select it (85,89, 90,95) via [+] or [-] key.
- ③ Press the [Mode changeover] key to return to the standby state.

2-5-8 Select the sheet size

- ① When [Parameter setting] key is pressed eleven times, the LCD will show

sheet size :
A4

- ② Select it (A4) via [+] or [-] key.
- ③ Press the [Mode changeover] key to return to the standby state.

2-5-9 Select the cutting column

- ① When [Parameter setting] key is pressed twelve times, the LCD will show

Cutting column:
X

- ② Select it (2) via [+] or [-] key.
- ③ Press [Mode changeover] key to return to the standby state.

2-5-10 Factory setting loaded

- ① When [Parameter setting] key is pressed thirteen times, the LCD will show

Factory setting loaded

② Press [+], [-] key, the ex-works set-up is recovered and the machine is restarted or press [Mode changeover] key to give up and return to the standby state.

2-5-11 Customize mode Operation method

① Continue pressing the [Mode changeover] key till the LCD displays:

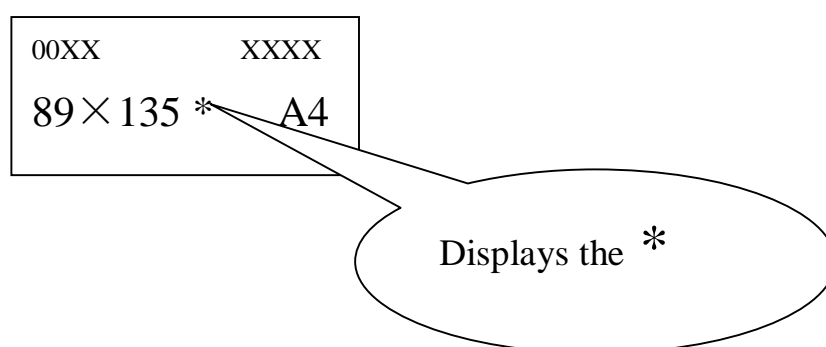

② Press [Parameter setting] button and hold for more than 2 seconds, till the LCD displays:

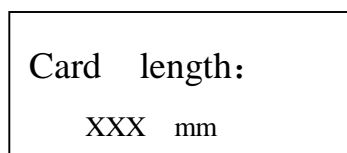

③ Adjust it via [+] or [-] key (Note: Press [+] or [-] button and hold for more than 1 second, can be quickly adjusted) .

④ Press [Parameter setting] key, till the LCD displays:

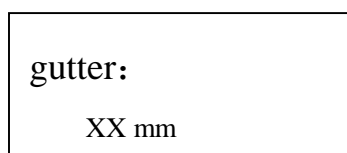

⑤ Adjust it via [+] or [-] key.

⑥ Press [Parameter setting] key, till the LCD displays:



- ⑦ Adjust it via [+] or [-] key.
- ⑧ Press the [Mode changeover] key to return to the standby state.

2-6 Way of operations and flow

(1) Input the power

When the power is turned on, the machine starts initiating and gets into the standby state.

(2) Set-up of the paper

Make the paper to be cut aligned and into the paper feeding desk with the printed face upward.

- a. Paper width adjustment: with the side of the paper lightly touched with the paper guide plate.
- b. Do not place too many papers on the said desk.
- c. Paper feeding may be affected with the frontal end of the paper rolled upward, do not put it in till its being flatted.
- d. Do not place papers of different kinds at the same time, or paper feeding may be affected.
- e. Do not use plastic sealed paper, film coated paper, PVC paper and those too thick or too hard, or the cutter may cause damage.

- ① Micro-adjusting nut of paper guide plate
- ② Left paper guide plate
- ③ Right paper guide plate
- ④ Aligned mark

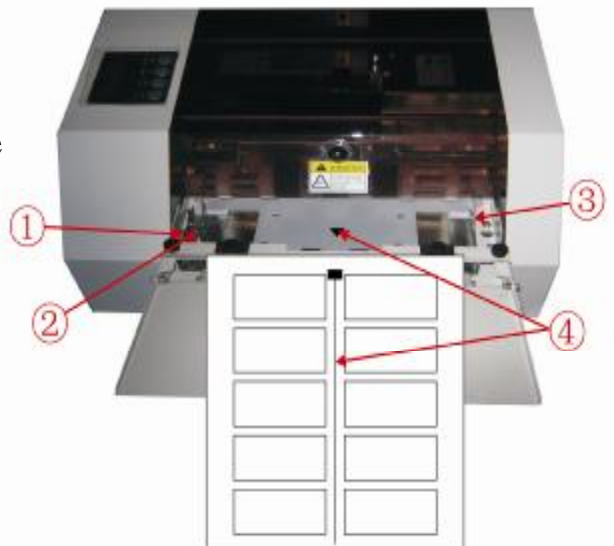

(3) Set-up of both right and left positions of paper

Move both left and right paper guide plates to suit the paper size and the 2 triangle marks on the paper feeding tray aligned with the center of the card cutting place in the first line. Use the micro-adjusting nut on the paper guide plate to adjust the paper tightness.

(4) Paper feeding and cutting



Do not let your hand or hairs close to the first paper feeding stick at paper feeding and cutting so as to avoid injury.



Do not take anything out with your finger at paper feeding and cutting.

- ① After setting the paper mode, press <start> key and cutting upon the set size will be started. The machine will automatically stop at the end of cutting and stay at the standby state. Press the key again to start another cutting.
- ② At the end of cutting, the whole flow finishes. Please turn off the power.

2-7 Way to load and unload the rotary blade assembly

2-7-1 Please follow the flow below when to unload the assembly



Make sure of the power to be cut off so as to avoid electric shock.



Never touch the cutter to avoid injury. Take care of it in operation.

- ① Turn off the power switch.
- ② Remove the top cover.
- ③ Remove 4 fixing screws on the assembly.
- ④ Take the assembly out from the side of the casing.

2-7-2 Please follow the flow below when to load the assembly

- ① Put the assembly in obliquely through the long hole on the counter operational surface and mount it neatly. Make sure of the gears to be completely matched.
- ② Fix the 4 fixing screws.
- ③ Put on the top cover.
- ④ Turn on the power and see if there is an abnormal sound.

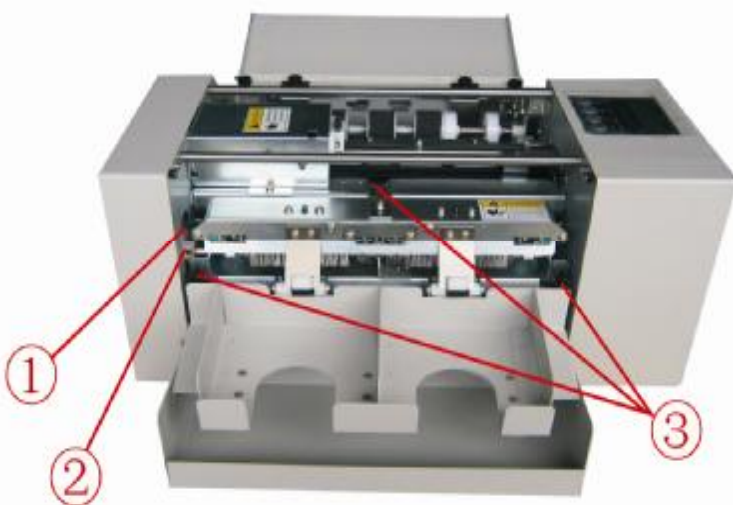

- ① oblong hole
- ② gears
- ③ screw

2-8 Way of adjustment to cut different thickness of paper

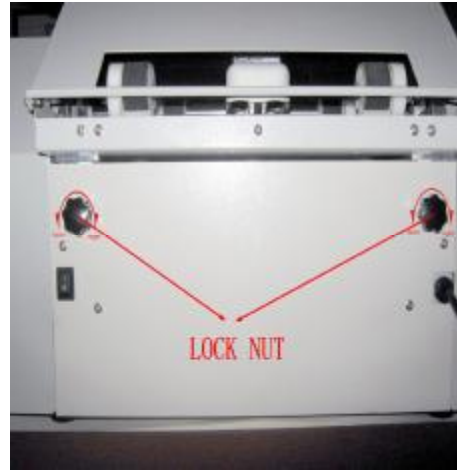

When out of factory, the thickness adjustment needle points to the middle, which means cutting 250g (about 0.25mm) thickness paper.

(A) If cutting paper that thicker than 250g (or 0.25mm):

- ① Loosen the lock nut;
- ② Rotate the needle to "+" direction by cross-screwdriver; (It's 0.02mm thickness corresponding to each space)
- ③ Tighten the lock nut.

(B) If cutting paper that thinner than 250g (or 0.25mm):

- ① Loosen the lock nut
- ② Rotate the needle to "-" direction by cross-screwdriver. (It's 0.02mm thickness corresponding to each space)
- ③ Tighten the lock nut.

3 Troubleshooting

The buzzer will sound in case of a mistake with the safety device or paper jamming and the content of it will be shown on the liquid crystal screen and the machine will be changed to stop or stay at the standby state.

3-1 Safety cover fails

If the top cover is off, there will be buzzer sound.

Settlement: Turn off the power, put on the top cover, then turn on the power.

3-2 Settlement of paper jamming

(A) Settle it upon the way below in case of internal paper jamming

- ① Turn off the power.
- ② Remove the top cover.
- ③ Remove the longitudinal cutter assembly and take out the jammed paper.
- ④ Put the top cover back on.
- ⑤ Turn on the power and press <start> key.
- ⑥ Confirm the jammed paper and chips have been taken out.
- ⑦ Turn off the power.
- ⑧ Open the top cover.
- ⑨ Mount the assembly.
- ⑩ Put on the top cover.
- (11) Turn on the power and see if there is an abnormal sound.

(B) Settle it upon the way below in case of paper jamming with the paper feeding tray

- ① Turn off the power.
- ② Take out the paper piled up on the tray.
- ③ Pull the jammed paper outward.
- ④ Turn on the power and press<start> key, the paper feeding motor starts working. Please make sure if there is an abnormal sound.

3-3 Long blade jam

Reason: There is residual paper inside; too thick paper, too rolled paper.

- ① When the LCD shows: Long blade jam,

Press [Mode changeover], the LCD will show:

<M>:EXIT <S>: ↓
<+>·← <->·→

- ② Press [Parameter setting] key and select [+] or [-] key to settle the problems:

Press [Mode changeover] to EXIT; Press [Parameter setting] to make long blade work (press once for each cutting); Press [+] to forward paper; Press [-] to afterward paper (press once for each step); Press the [Mode changeover] key to return to the standby state.

- ③ Press the [Mode changeover] key to return to the standby state.
- ④ Restart the machine after the settlement upon (A) internal paper jamming in 3-2 settlement of paper jamming.

3-4 Black Mark■ not detected

Reason: In the mark ■ detection mode, the mark ■ is not printed or does not conform to the set requirement.

① When the LCD shows: Black Mark■ not detected

Press [Mode changeover], the LCD will show:

<M>:EXIT	<S>: ↓
<+>:←	<->:→

② Press [Parameter setting] key and select [+] or [-] key to settle the problems:

Press [Mode changeover] to EXIT; Press [Parameter setting] to make long blade work (press once for each cutting); Press [+] to forward paper; Press [-] to afterward paper (press once for each step); Press the [Mode changeover] key to return to the standby state.

③ Press the [Mode changeover] key to return to the standby state.

④ Use the frontal end datum detection; Or make the printed mark ■ conform the set requirement.

3-5 Mark sensor failed

Reason: In the mark ■ detection mode, non-white paper is used.

① When the LCD shows: Mark sensor failed,

Press [Mode changeover], the LCD will show:

<M>:EXIT	<S>: ↓
<+>:←	<->:→

② Press [Parameter setting] key and select [+] or [-] key to settle the problems:

Press [Mode changeover] to EXIT; Press [Parameter setting] to make long blade work (press once for each cutting); Press [+] to forward paper; Press [-] to afterward paper (press once for each step)

Press the [Mode changeover] key to return to the standby state.

③ Press the [Mode changeover] key to return to the standby state.

④ Use the frontal end datum detection; Or use white paper under the mark ■ detection mode

3-6 Paper is too narrow

Reason: In the mark ■ detection mode, non-white paper is used.

① When the LCD shows: Mark sensor failed,

Press [Mode changeover], the LCD will show:

<M>:EXIT <S>: ↓
<+>:← <->:→

② Press [Parameter setting] key and select [+] or [-] key to settle the problems :

Press [Mode changeover] to EXIT; Press [Parameter setting] to make long blade work (press once for each cutting); Press [+] to forward paper; Press [-] to afterward paper (press once for each step)

Press the [Mode changeover] key to return to the standby state.

③ Press the [Mode changeover] key to return to the standby state.

④ Use the frontal end datum detection; Or use the standard paper.

3-7 Bad paper feeding

(A) The paper guide plate is made too tightly, use the micro-adjusting nut to readjust it.

(B) Paper feeding problem may occur in case of an improper paper. Please conform to the followings.



- ① Too thick (over 0.30mm), too thin (below 0.20mm)
- ② Too small or too big size of paper
- ③ Too many papers are placed. No more than 3mm and no more over the red line.
- ④ Excessively rolled paper

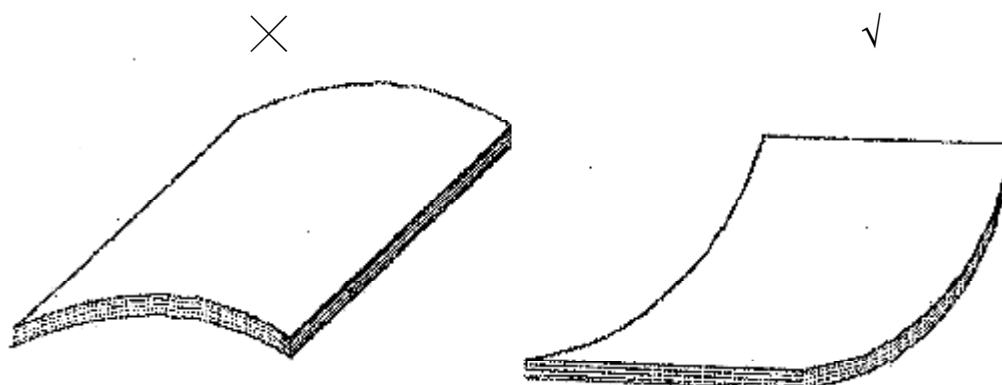

Please do not use the paper shown above, or else bad paper feeding, bad cutting, non-aligned paper etc failures would occur.

【Can not use】 : Laterally rolled paper.

【Can use】 : Longitudinally rolled paper, but, the rolled degree is limited within 5mm and the rolled portion must be made flatted.

4. After-care

4-1 Warranty

Machine (main unit): Guaranteed for 6 months after purchase or cutting of 500,000 times (whichever comes first).

Rotary blade: Guaranteed for 6 months after purchase or cutting of 1000,000 times (whichever comes first).

Long blade: Guaranteed for 6 months after purchase or cutting of 1000,000 times (whichever comes first).

4-2 Maintenance service

Repairs are made free of charge for 6 months after purchase or cutting of 500,000 times whichever comes first.

The rotary blade and long blade are repaired free of charge up to a paper cut count of 1000,000 times.

4-3 Units with specified replacement periods

Long blade: Generally should be replaced after cutting approximately 1000,000 times.

Rotary blade: Generally should be replaced after cutting approximately 1000,000 times.

5 System troubleshooting analysis

1: Normal use method, Paper requirements, Content Error Adjustment method.

1): Take the machine out the box, then put it on the iron case, the rubber pad shall align at the hole. The machine's after end shall also shall subtend the square hole so that the wasted paper can fall into the iron case successfully. The carton also can put into the iron case as a wastebasket. It's good for daily cleaning. At last, hanging the card collection box over the side iron plate which back of the machine.(Rotary Blade direction). Switch on the power, open the machine (Voltage range 90v--260v). Spread the paper tray. Move the paperboard to match the paper size. Revolve the left nut in order to the adjust the paper elasticity. (Do not too tight). the printed card paper's first column cutting place shall align at the triangle mark. Press the "Model changeover "key to find the right cutting specifications, then press the "Set parameter "key to set the paper sheets.(Can put 1-12 pieces at once,do not put more than red line).

2): Paper requirements:Paper thickness : 0.25mm--0.35mm or 180gsm--350gsm.The paper shall be level.do not crimp or too damp.the paper thickness must be the same , can not be skewed.

3): How to adjust the card content error

A: When the card outside diameter size is consistent, but the cards' side content error is overlarge or dew, we need confirm the printed content whether match the factory setting..then move the paperboard. if the content is inclined left, move the paper to the right side.And vice verse.To find the best position.(If it is the SSA-003-I Model or the SSA-001-I Model, it needs lock the black screw to match the paper putting place).

B: When the card outside diameter size is consistent, but the front and back content error is oversize or dew, we also shall confirm the printed content. According to the deviation size to adjust.If the error is forward gradually, like the first card is 0.2mm., the second is 0.4mm, but the third is 0.6mm and so on, we shall adjust the groove compensation. Press the "Set parameter" key to find the Gutter compensation, then press the "-" key (A3+ press "▼") to reduce 0.2mm. If the card is backward deviation, like the first is 0.2mm.the second is 0.2mm, the second is 0.4mm ,the third is 0.6mm. we shall press the "+" key to add 0.2mm.(A3+ press "▲").

C: When the first card and the last cards' content error are the same. For example: the first card is forward 0.5mm, the second is forward 0.5mm too, but it's not increasingly large, we shall adjust the first

cutting compensation or sign position compensation. When the card is forward gradually 0.5mm from the front-end mode,press the "Set parameter" to choice the first cutting compensation, then press the "-" key to reduce 0.5mm. If the error comes form measure black mark mode,press the "Set parameter" to choice the sign position compensation, according to the above method of operation.

D: When the cards' corner is not be a right angle. We shall change the Rotary blade's place.

Method: Switch off the power,take off the head cover,loosen the two black screws, take apart the left cover,then loosen the screw which on the Rotary blade's fixed bracket. Then unscrew the screws which on the bottom left to adjust the angle. If the card was left inclined,move the screw like a counter-clockwise. If the card was right inclined, move the screw like a clockwise.

2: Change the two parts

1): How to change the Rotary blade: Standing in the switch direction. Switch off the power supply, take off the cover, loosen the four black screws by hand. Hold on the knife.lift the knife and pull it out.

Installation: Standing in the switch direction, switch off the power and hold the knife,let the cogged side blade align at the right

panel's long circle hole.and the another side of the blade closed to the rotary blade bracket. To make sure that the tooth could match the machine completely. Then tight the 4 screws.

2): The side cover's assemble and disassemble

Disassemble: take off the right cover (the side which has no operation panel called right cover).

Switch off the power, take off the head cover, loosen the two screws under the machine by "+"screwdriver. After that, loosen the other two inside screws on the machine and pull the cover out gently. The same method as the left cover. When set up ,we must put on the left cover first then clock the inside screws.

3): Replaced the Long blade assembly: Switch off the power and take off the the head cover, remove the left and right side cover. Dismantle the long blade shields, motor fixed frame and travel switch. Then tear down the left and right bracket and the under fixed screws by six concern screwdriver.pull out the wire,hold the motor and lift it slowly.

Setting up: Hold the motor and let the wire through the left panel. Then put up the motor,put the other side of the blade on the left bracket, put down the motor and clock the under screws. After that, setting up the long blade, travel switch, motor fixed frame and the

motor shields. The front of the triangle must put into the groove more than two-thirds.

4): How to change the long blade's motor : Switch off the power, take off the motor shields, motor fixed frame and travel switch.. Then loosen the triangle screws by six concern screwdriver, the triangle and screw shall put out together. With a screwdriver loosen the eccentric wheel direction's screws ,take the eccentric wheel out and loosen the three the panel's fixed screws .At last, pull out the wire.

Setting: set up the fixed screws, eccentric wheel, triangle, travel switch and motor fixed frame, motor shield successfully. Then insert the wire.

5): Stripper pad exchange: Use the "_" screwdriver to move the rubber roller to another side then lift, put out the rubber roller, take off the leather,exchange a new leather, the bearing side should be align at the rubber roller's connector.

6): How to change the give paper round: Open the head cover, move the pressure roller to both side,push the pressure roller barb so that it can move when it break away from the groove. Pull out the paper shaft and insert it. Pay a attention to the direction. (when the paper shaft stop naturally, pressure roller shall be planed

down.)

3: Trouble removal (Normally)

1): The paper can not enter into the machine or it just get into 2 pieces or 3 pieces at once.

Reason: When the paper thickness is exceed 0.25mm, the paper can not enter into the machine smoothly. Or the paper thickness less than 0.25mm, it will just get into the machine 2 or 3 paper.

Method: when the paper cannot get into the machine successfully, take off the head cover, loosen the fixed screws of the power switch, put down the paper on the paper plate and move the paperboard to the middle so that we can find the under pointer. Then move the pointer like a anticlockwise by "+" screwdriver.(the pointer is in the dead center by factory setting, every turn increase by 0.25 mm). According to the paper thickness to find the right number, then clocked the screws. On the contrary, when it just enter into 2or 3 pieces at once,we shall move the pointer like clockwise.then do like the above method.

2): When press the "start" key, but the paper round just move an half-turn and the paper can not get into the machine. It's due to the wire is bad contact. So we shall open the left side cover(the side which has the operate key called left side cover)to find the CN5

model on the circuit board, check the wire whether loose or not, if it loose, insert it.

3): When the machine start, but the operation boundary shows the paper planet was wrong. it also due to the wire is bad contact, do the same as the second method.

4): If the machine shows the cover is open when it start, it's because that the head cover is not cover or the motor shield wire is bad contact. We shall close the head cover and confirm the sheet iron insert the shield's hole completely. If it can not be solved, we shall open the left cover to check the wire. If it was loosed,closed it.

5): The long blade failed cutting when the machine start. Reason: the triangle iron is not match the travel switch's groove or it insert too less. Method: open the right cover,loosen the the travel switch bracket's screws, push down the switch to make sure the triangle iron is match the groove more than two-thirds.

6): When the long blade is working, but the paper can not cut and the boundary shows "fail cutting", it's because that the paper thickness is too large , there are some wasted paper still in the blade or the paper jam. Clean up the wasted paper and change the paper. If it could not be done, take down the long blade assembly,

loosen the screws and the triangle iron, move the blade forced to make the it running. When the blade running smoothly, reset the blade.

7): When it show the “paper jam”, there are some wasted paper still in the machine or the wire is bad contact. tear down the long blade assembly, clean up the wasted paper .Open the left cover to check the wire.

8): When it show the paper is too narrow, that means the paper are not wide enough or the paper are not put at the right position. Adjust the paperboard to find the right position.

9): If the machine can not test the black mark: In the black mark test model,the paper composing may not print as the instruction or the clour is not too deep. So the paper composing shall be printed according to the instruction. (If it was A4 model, the black mark must align at the triangle mark(it will be find at the paper tray)).

10): The trouble with the senor, this situation just come from the black mark test model. It's due to the clour is too deep or the paper is too black,we shall use a tint paper to print(according to the clour instruction) or choose the front test model to cut the paper.